

**PROGRESSIVE METALLIZING  
& MACHINE**



**DAVID M. DATSKO**  
OWNER  
DMD@PROREBUILD.COM



D: 330-784-4717      300 MASSILLON RD  
 C: 330-472-1110      AKRON, OH 44312  
 F: 330-784-4728      WWW.PROREBUILD.COM

**ROD PRESS FORM  
PRESS NUMBER:**

- A. OVERALL HEIGHT: 75"
- B. WIDTH: 40"
- C. FLOOR TO BOLSTER HEIGHT: 40"
- D. TOTAL OPENING WITHOUT: 21"
- E. MAXIMUM SINGLE OPENING: 16"
- F. RAM DIAMETER: 20"
- G. ROD DIAMETER: 4.5"
- H. STROKE: 20"

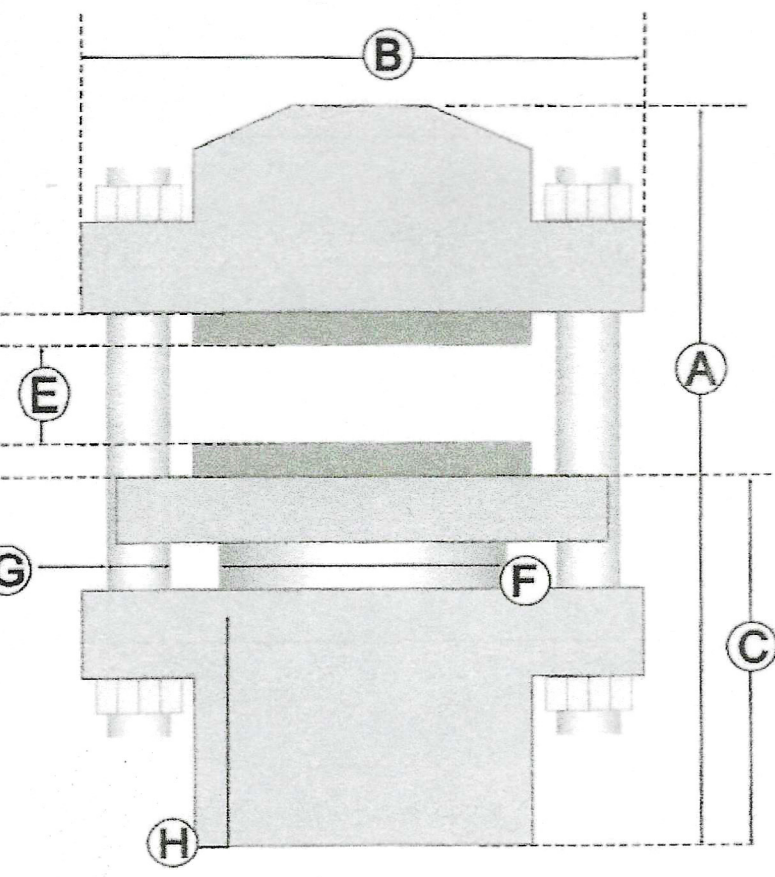

**DISTANCE BETWEEN RODS**  
L/R:

**PLATENS**  
# OF PLATENS: (2) 24" x 26"  
THICKNESS:  
L/R:  
F/B:  
TYPE: electric

**SERVICE:**  
 OIL  
 WATER  
 WATER SOLUBLE

**MFG:**  
  
**MAXIMUM WORKING PRESSURE (PSI): 2200**

**ESTIMATED WEIGHT:**  
  
**TYPE OF GUIDING: fully-guided**

**COMMENTS:**

315 tons @ 2000 psi